

INVERTER FR-E700-SC(-EC)(-NA)/NF/NC

Safety Stop Function Instruction Manual

CONTENTS

1. GENERAL DESCRIPTION	2
2. INSTALLATION AND WIRING	3
3. EXAMPLE OF SAFETY SYSTEM CONFIGURATION	6
4. TEST AND CHECKING FAILURE	11
5. SAFETY PARAMETERS OF FR-E700-SC/NF/NC	12

Compliance with the EU Machinery Directive – Functional Safety

⚠️ WARNING

- Any misuse of safety function could lead to personal injury or death, property damage, or economic loss. To ensure that the system complies fully with requirement of safety, make a system-level risk assessment. Mitsubishi Electric Co. cannot assume responsibility for any system to comply with safety standards.
- To avoid an electric shock hazard, verify that the voltage on the bus capacitors has discharged before performing any work on the drive. Measure the DC bus voltage at the P(+) and N(-) terminals or test points (refer to your drive's *User Manual* for locations and discharging time). The voltage must be zero.
- The safety stop function do not isolate electrically between drive and motor. To avoid an electric shock hazard, disconnect/isolate power to the drive and verify to ensure that the voltage is zero before performing any work on the motor (refer to your drive's *User Manual* for discharging time).

⚠️ CAUTION

- The information of this manual is merely a guide for proper installation.
- Mitsubishi Electric Co. cannot assume responsibility for the compliance or the noncompliance to any code, national, local or otherwise for the proper installation of this equipment.
- A hazard of personal injury and/or equipment damage exists if codes are ignored during installation.

⚠️ CAUTION

- FR-E700-SC/NF/NC which has the following SERIAL number are compatible with ISO13849.

<FR-E700-SC/NF/NC series of Japanese specifications>
FR-E700-SC: F or later
FR-E700-NF: E or later
FR-E700-NC: Three-phase 200V class 0.1K to 0.75K: C or later
Three-phase 200V class 1.5K to 3.7K/11K/15K: B or later
Three-phase 200V class 5.5K/7.5K: D or later
(Three-phase 400V class and single-phase 200V class are all compatible.)

<FR-E700-SC series of NA, EC specifications>
Compatible for all models.

- Diodes are installed to S1 and S2 terminal of the following FR-E700-SC/NF/NC to block undesirable current.

<FR-E700-SC/NF/NC series of Japanese specifications>
FR-E700-SC: Manufactured in November 2010 or later
FR-E700-NF: Manufactured in December 2010 or later
FR-E700-NC: Three-phase 200V class and
single-phase 200V class: Manufactured in November 2010 or later
Three-phase 400V class: Manufactured in October 2010 or later

<FR-E700-SC series of NA, EC specifications>
Manufactured in August 2010 or later

Check the SERIAL number indicated on the inverter rating plate or package.

Rating plate example

□	○	○	○○○○○○
Symbol	Year	Month	Control number

—————
SERIAL (Serial No.)

The SERIAL consists of one symbol, two characters indicating production year and month, and six characters indicating control number.
The last digit of the production year is indicated as the Year, and the Month is indicated by 1 to 9, X (October), Y (November), and Z

1. General description

Features

Mitsubishi Electric FR-E700-SC/NF/NC safety stop function prevents a drive from supplying rotational energy to motors. (In this Instruction Manual, the STO (safe torque off) function specified in IEC 61800-5-2 is referred to as the safety stop function.)

Dual safety channels 'S1' and 'S2' cut off the gate-drive power for IGBT to turn off.

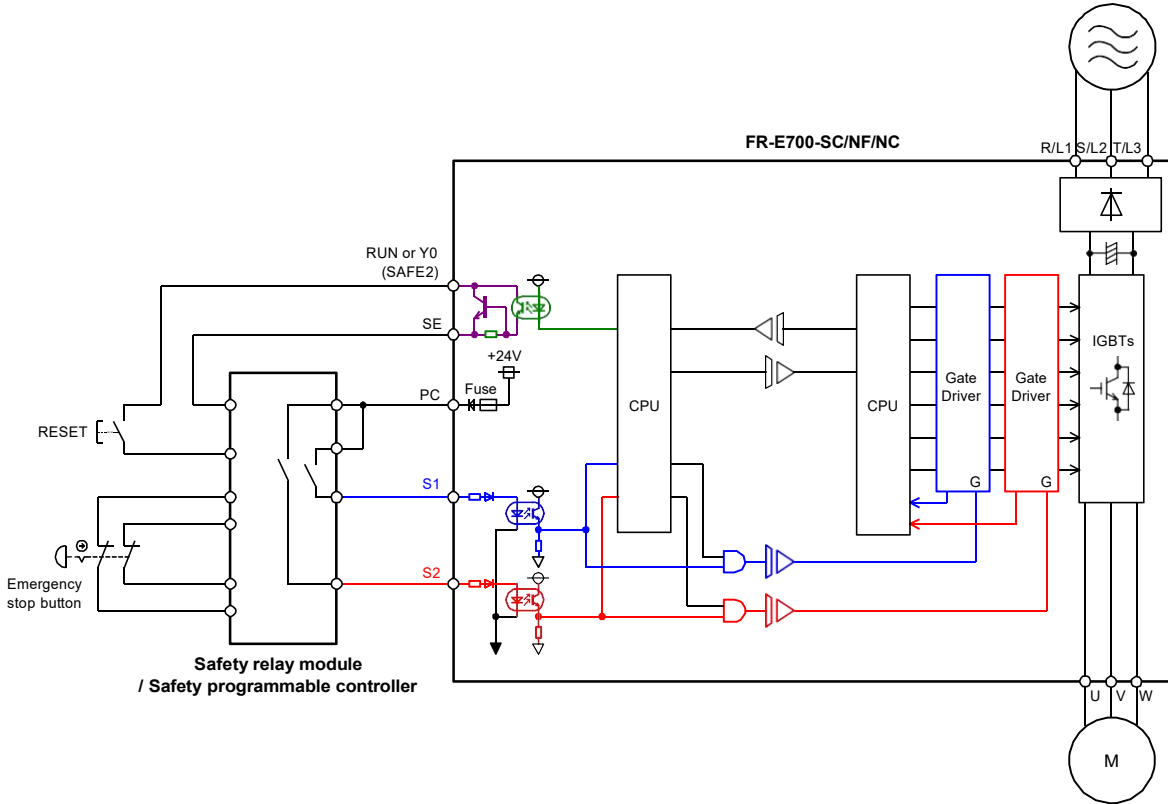

Fig.1 FR-E700-SC/NF/NC safety stop function diagram

⚠ WARNING

- Disconnecting the power to the gate driver by the safety stop function does not isolate electrically between drive and motor. To avoid an electric shock hazard, disconnect power to the drive and verify that the main circuit capacitor voltage is zero (across P and N terminals) before performing any work on the motor (refer to your drive's *User Manual* for discharging time).

Standards

Mitsubishi Electric FR-E700-SC/NF/NC safety stop function meets the following standards and categories.

ISO13849-1:2015 Category 3/PLd

IEC62061:2021 / IEC61800-5-2:2016 / IEC61508:2010 SIL2

IEC61800-5-2:2016 Stop category 0

⚠ WARNING

- The misuse of safety function leads to personal injury or death, property damage, or economic loss. To ensure that the system complies fully with requirement of safety, make a system-level risk assessment. Mitsubishi Electric Co. cannot assume responsibility for any system to comply with safety standards.

2. Installation and wiring

⚠ CAUTION

- The following information is merely a guide for proper installation.
Mitsubishi Electric Co. cannot assume responsibility for the compliance or the noncompliance to any code, national, local or otherwise for the proper installation of this equipment.
A hazard of personal injury and/or equipment damage exists if codes are ignored during installation.
- Ensure the safety relay unit and the FR-E700-SC/NF/NC unit is mounted closely in enclosure meeting IP54 and all interconnection wiring is short and protected against open and short circuit faults.
Refer ISO/IEC13849-2.

Installation

Mitsubishi Electric FR-E700-SC/NF/NC safety stop function should be used under following condition and environment.

Table.1 The condition and environment for using safety stop function

Item		Condition
Temperature range	Operation	-10°C to +50°C (non-freezing)
	Storage	-20°C to +65°C
Ambient humidity		90%RH maximum (non-condensing)
Vibration		5.9m/s ² or less
Altitude		maximum 1000m
Atmosphere		Indoors (without corrosive gas, flammable gas, oil mist, dust and dirt etc.)
Over voltage category		II or less
Pollution degree		II or less
Mounting		wall mounting / vertical orientation

⚠ WARNING

- To avoid an electric shock hazard, insert the magnetic contactor (MC) between power source and drive.
- Open the contact of MC and keep away from drive for discharging time (refer to your drive's *User Manual* for information) before performing any work on the drive. And verify that the voltage on the bus capacitors has discharged before Measure the DC bus voltage at the P(+) and N(-) terminals or test points (refer to your drive's *User Manual* for locations). The voltage must be zero.

⚠ CAUTION

- In order to meet safety stop, an approved safety relay unit to ISO13849-1/EN954-1 safety category 3 or better shall be used in conjunction with FR-E700-SC/NF/NC as shown in example.
In addition, all other components with in the safety stop loop shall be 'safety approved' types.
- To avoid systematic faults, a test even for faulty demands of the safety function has to be performed in order to check the correct function of the monitor signal. This test shall be carried out at system installation, any software changes, parameterization changes, and/or at least once per year.
Refer to '4. Test and checking failure'.

Wiring

The safety related terminals are described in Table.2 and Table.3

Table.2 The safety related terminals

Terminal Symbol	Description	Rating *2
S1	For input of safety stop channel1. S1-PC is Open: In safety stop mode. Short: Non safety stop mode.	Input resistance: 4.7kΩ Input Current : 4 to 6 mA (In case of shorted to PC) Input Voltage : 21 to 26.5 V
S2	For input of safety stop channel2. S2-PC is Open: In safety stop mode. Short: Non safety stop mode.	
PC	Common terminal for S1,S2 signals. *PC is connected to 24V power source through diode and fuse.	Output Voltage 22V to 26.5V Output Current : 100mA max.
RUN or Y0 (SAFE2)	As output for failure detection and alarm. RUN terminal type is 'Open collector output'. RUN or Y0-SE is OFF(Open): Detect failure or Alarm. ON(Close): No failure detected. Attention: To use RUN terminal or Y0 terminal for monitor output of failure detection, <u>Pr. 190 should be set "81" (Safety monitor 2).</u> Note: This terminal cannot be used to output safety outputs in a safety system. This terminal can be used for alarm or to prevent restart only, no other safety function.	Load: 24VDC/0.1A max. Voltage drop: 3.4V max. (In case of 'ON' state)
SE	Common terminal for RUN terminal and Y0 terminal.	
A, C *1 (SAFE2)	As output for failure detection. A,C terminal type is 'Relay output'. A-C is OFF(Open): Detect failure or Alarm. ON(Close): No failure detected. Attention: To use A,C terminal for monitor output of failure detection, <u>Pr. 192 should be set "81" (Safety monitor 2).</u> Note: This terminal cannot be used to output safety outputs in a safety system. This terminal can be used for alarm or to prevent restart only, no other safety function.	Load: 30VDC/0.3A max.

*1 The relay terminal is equipped for FR-E700-SC.

*2 Specifications for conforming safety standards.

Table.3 Truth table of Safety related signals

Input power	S1-PC	S2-PC	Internal safety circuit *1	RUN, Y0-SE or A-C (SAFE2) *2*3	Inverter operation state
OFF	-	-	-	OFF(Open)	Output shutoff (Safe state)
ON	Short	Short	No failure	ON(Close)	Drive enable
			Failure	OFF(Open)	Output shutoff (Safe state)
	Open	Open	No failure	ON(Close)	Output shutoff (Safe state)
			Failure	OFF(Open)	Output shutoff (Safe state)
	Short	Open	N/A	OFF(Open)	Output shutoff (Safe state)
	Open	Short	N/A	OFF(Open)	Output shutoff (Safe state)

"N/A" denotes a condition where circuit fault does not apply.

*1 At an internal safety circuit fault, one of E.SAF, E.6, E.7, and E.CPU is displayed on the operation panel. SA is displayed on the operation panel while S1 and S2 signals are both open and the safety function operates (without internal safety circuit fault).

*2 To use RUN or Y0 terminal for monitor output of failure detection, Pr. 190 should be set "81" (Safety monitor 2).

*3 To use A,C terminal for monitor output of failure detection, Pr. 192 should be set "81" (Safety monitor 2).

Wire and ferrule specification

Table.4 Wire and ferrule specification

Wire size (mm ²)	Ferrule with insulation sleeve *	Crimping tool name *
0.3	AI 0,34-10TQ	CRIMPFOX 6
0.5	AI 0,5-10WH	
0.75	AI 0,75-10GY	
1	AI 1-10RD	
1.25 / 1.5	AI1,5-10BK	
0.75 (combined 2 wire)	AI TWIN 2 X 0,75-10GY	

* Ferrules and tools are distributed by Phoenix Contact Co., Ltd.

Jumper cable

The jumper cable between S1,S2 and PC terminal has been installed in the factory as shown in Fig.2.

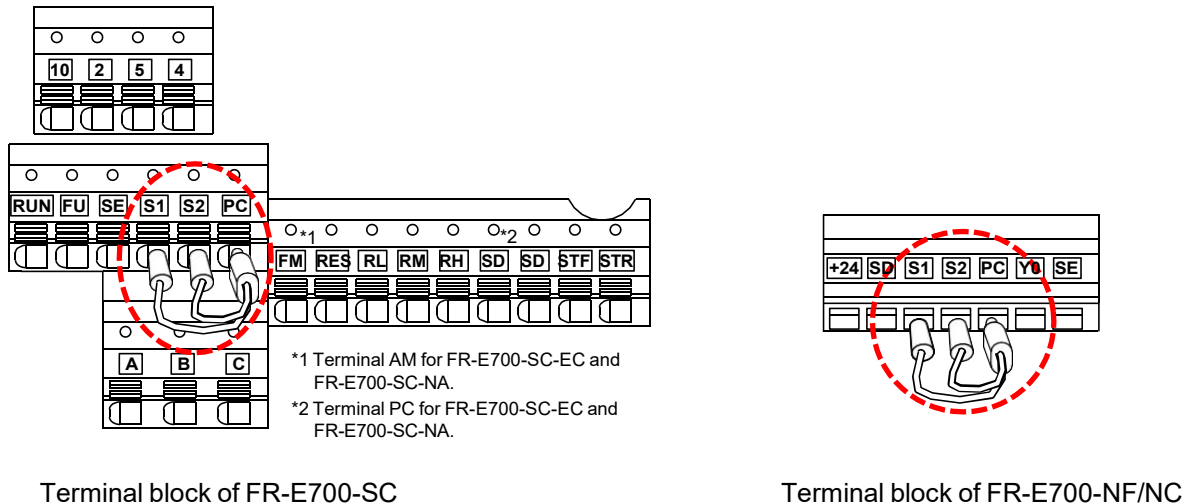

Terminal block of FR-E700-SC

Terminal block of FR-E700-NF/NC

Fig.2. Short wire

Before connecting safety input wire to S1,S2 and PC terminal, remove this jumper cable.

3. Example of safety system configuration

•FR-E700-SC configuration example

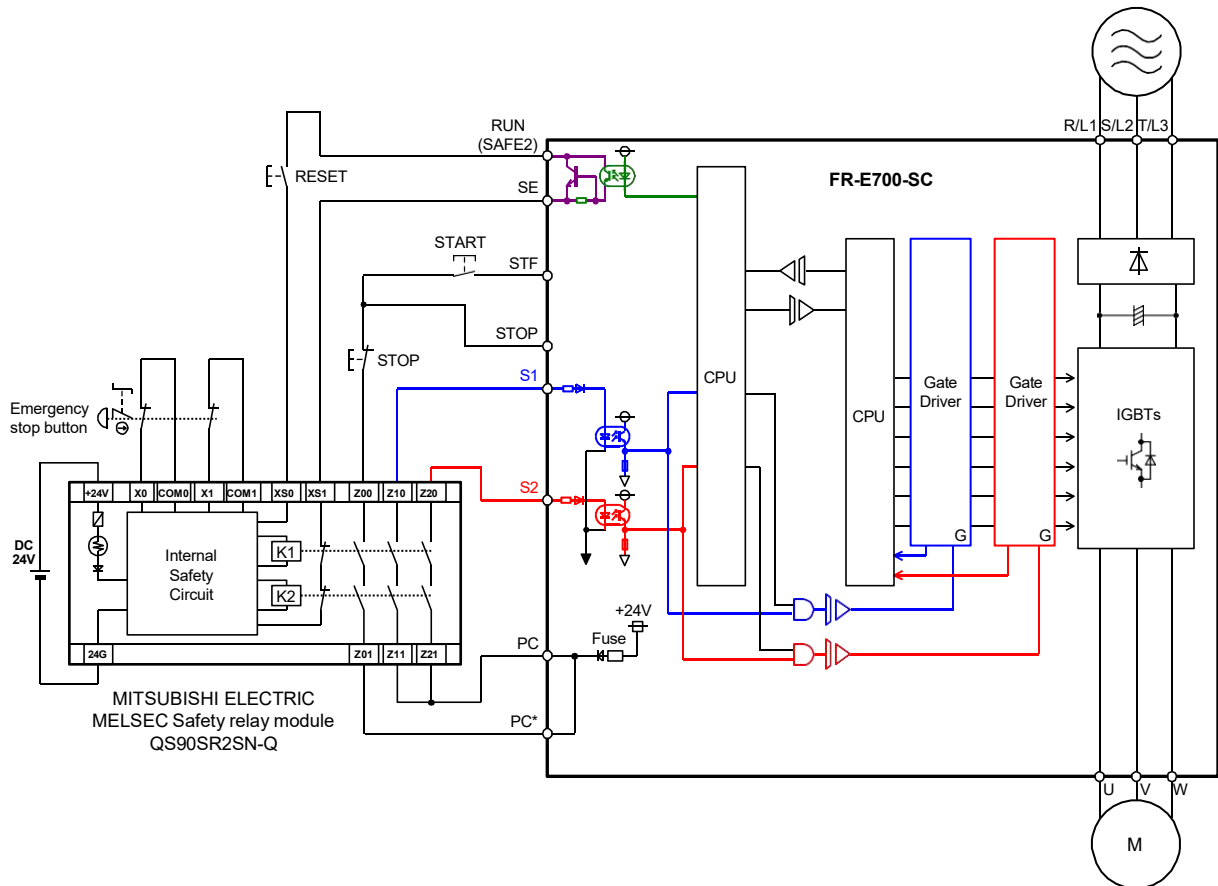

* If the control logic is SINK logic, the common terminal is terminal SD.

Fig.3 Safety system example with FR-E700-SC



NOTE

- To use RUN terminal for monitor output of failure detection, Pr. 190 must be set to "81". This setting makes the RUN-SE output to open in case of failure.
- When starting up the system's operation, press the RESET switch to reset the safety stop function first, then turn ON the START switch to run the motor.
- In the above configuration, after reset of emergency stop button, drive will be in safe-state until RESET switch is pressed.

⚠ CAUTION

- To prevent restart in case of recovering from input power loss of drive, 3-wired connection for START/STOP control is recommended. In case of 2-wire connection and using latching type switch to short between STF and SD/PC for starting, ensure the compliance with safety requirement for the restarting when the drive recover from input power loss.

•FR-E700-NF/NC configuration example

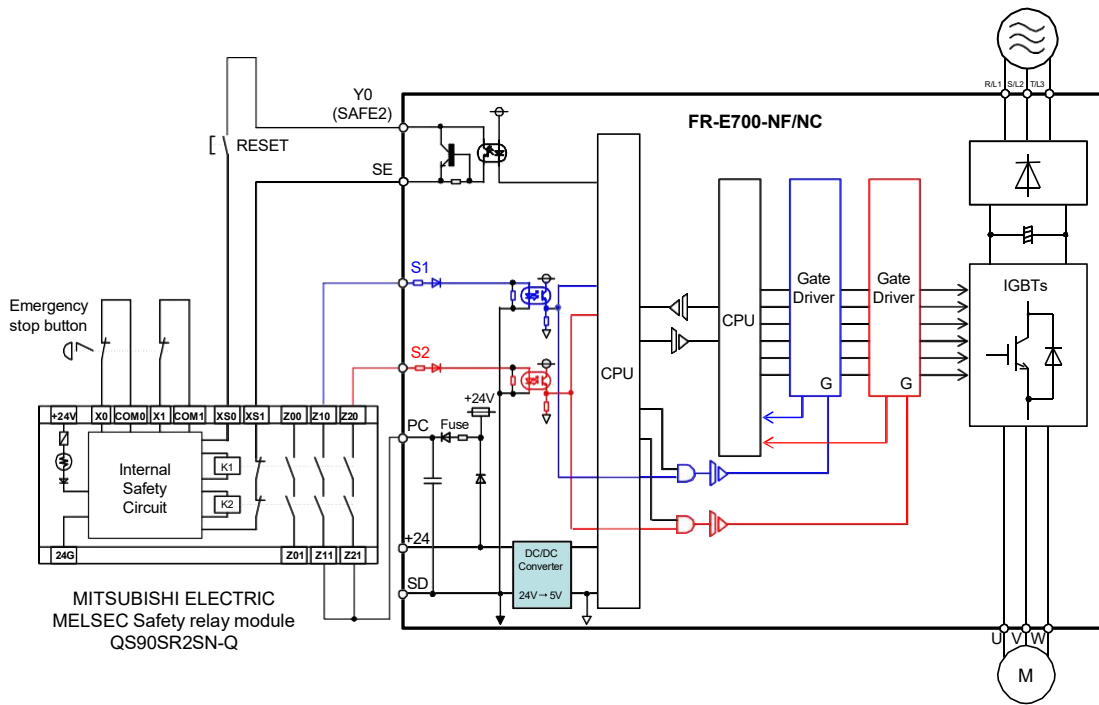

Fig.4 Safety system example with FR-E700-NF/NC



NOTE

- Set Pr. 190 to "81" to use FR-E700-NC's Y0 terminal to monitor fault detection. (The setting is not required for FR-E700-NF.) This setting makes the Y0-SE output to open in case of failure.
- When starting up the system's operation, press the RESET switch to reset the safety stop function first.
- In the above configuration, after reset of emergency stop button, drive will be in safe-state until RESET switch is pressed.

• Multiple inverter configuration example

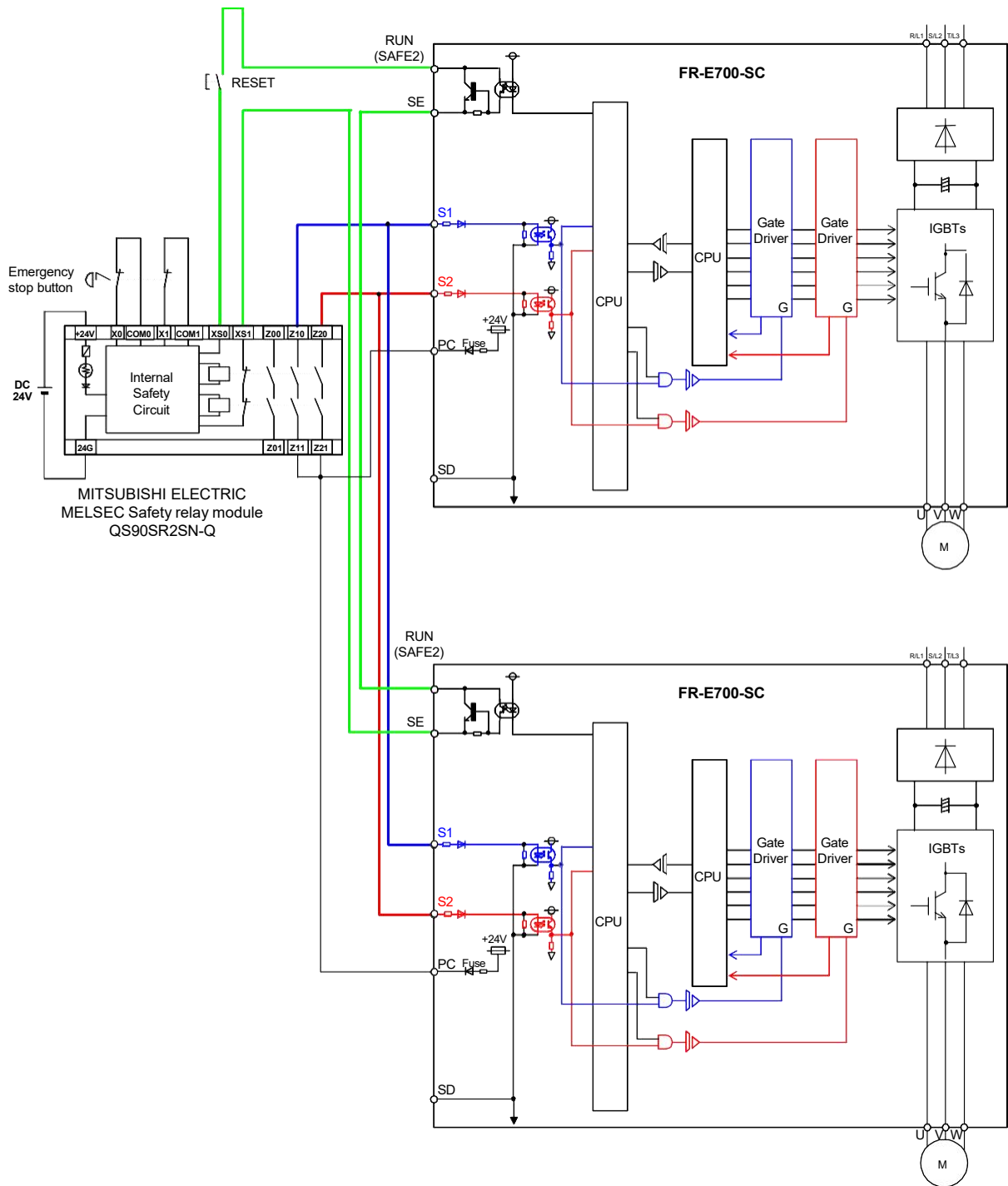

Fig.5 When using multiple safety stop function inverters (FR-E700-SC)



NOTE

- If an inverter with current-blocking diodes installed to S1 and S2 terminal are used with an inverter without the diodes, the safety stop function may not work properly. To use an inverter without diodes in combination with a diode-installed inverter, install the diodes to the inverter's output shutoff signals (S1 and S2 terminal). Refer to page 1 to find out which models are diode-installed models. For the diode specifications, refer to page 9.
- Do not connect the FR-D700 (sink logic) together with the FR-E700-SC/NF/NC (source logic). If connected together, the safety stop function does not work properly. (Refer to page 10.)

• Configuration example with multiple inverters (without diodes to block undesirable current)

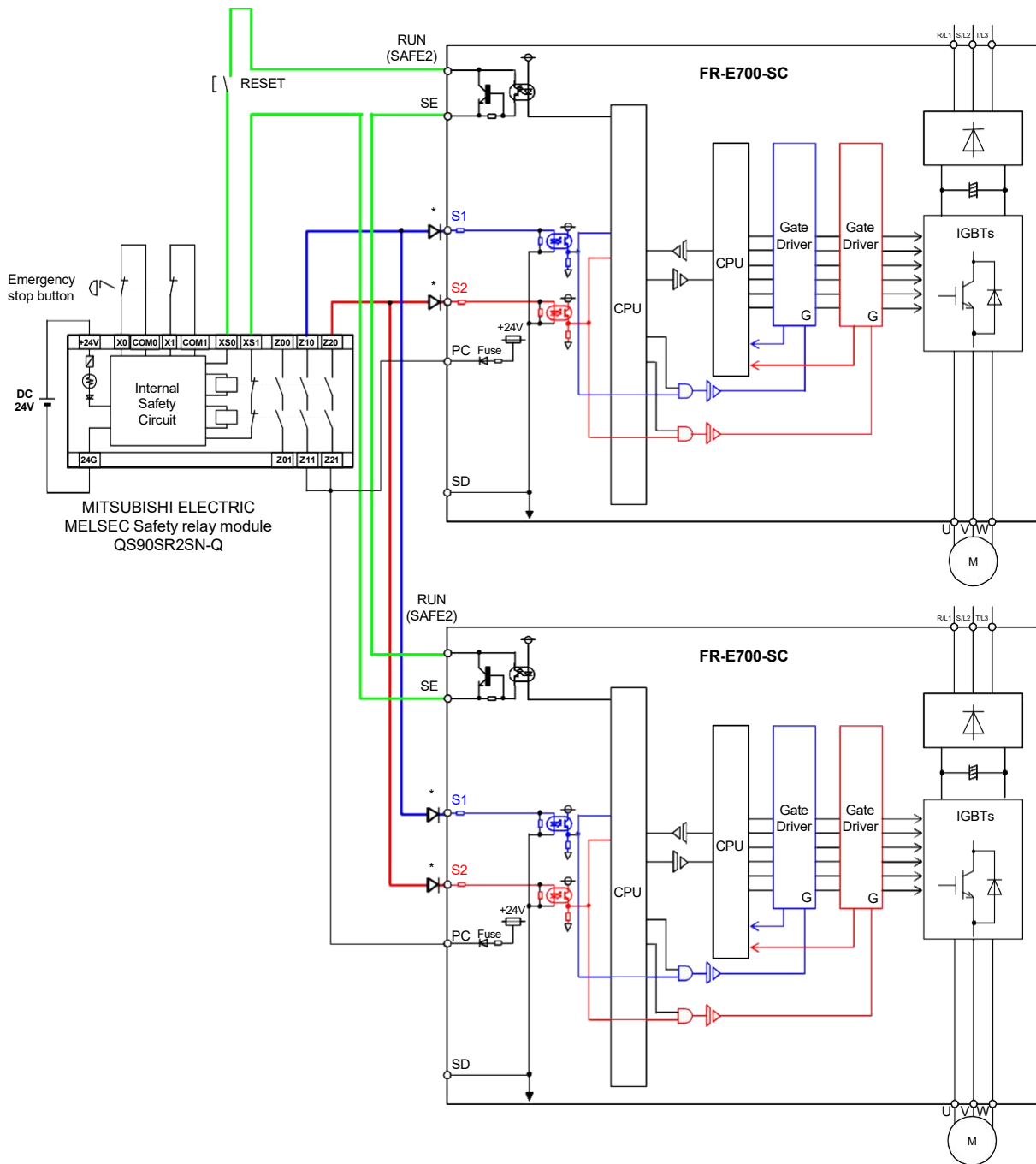

* When connecting multiple inverters, use a diode on each safety input terminal to prevent a malfunction due to undesirable current. Refer to the following for the specification of the diode.

Diode type : P-N junction type (Do not use a Schottky barrier diode.)

Electronic specification - Peak reverse voltage (V_{rrm}) : 50V or more, Peak forward voltage (V_f) : 1V or less (at 5mA),

Effective forward current (I_f) : 100mA or more

Fig.6 When using multiple safety stop function inverters (FR-E700-SC)



NOTE

- Refer to page 1 to find out which models are diode-installed models.
- The number of inverters connected to a safety relay unit should be decided under considerations of output terminal rating of a safety relay unit.
- Do not connect the FR-D700 (sink logic) together with the FR-E700-SC/NF/NC (source logic). If connected together, the safety stop function does not work properly. (Refer to page 10.)

• Safety controller configuration example

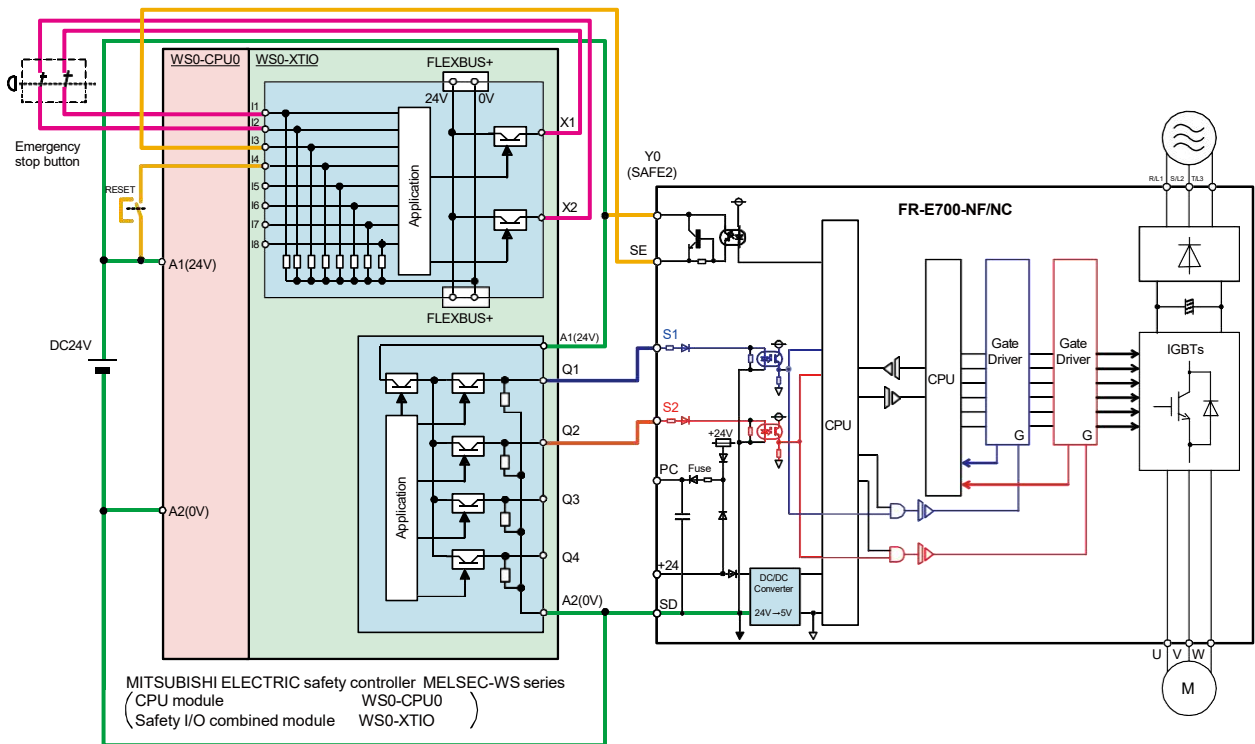

Fig.7 Safety system example with FR-E700-NF/NC



NOTE

- Set Pr. 190 to "81" to use FR-E700-NC's Y0 terminal to monitor fault detection. (The setting is not required for FR-E700-NF.) This setting makes the Y0-SE output to open in case of failure.
- When starting up the system's operation, press the RESET switch to reset the safety stop function first.
- In the above configuration, after reset of emergency stop button, drive will be in safe-state until RESET switch is pressed.

• Inverter connection

Do not connect the FR-D700 (sink logic) together with the FR-E700-SC/NF/NC (source logic). If connected together, the safety stop function does not work properly.

	FR-E700-SC/NF/NC (source logic)	FR-D700-SC (source logic)	FR-D700 (sink logic)
FR-E700-SC/NF/NC (source logic)			
FR-D700-SC (source logic)			
FR-D700 (sink logic)			

: Enabled, : Disabled

4. Test and checking failure

⚠ CAUTION

- To avoid systematic faults, a test even for faulty demands of the safety function has to be performed in order to check the correct function of the monitor signal. This test shall be carried out at system installation, any software changes, parameterization changes, and/or at least once per year.

I/O status and failure

FR-E700-SC/NF/NC safety related I/O status obeys the following truth table.

Table.5 Truth table of Safety related signals

Input power	S1-PC	S2-PC	Internal safety circuit *1	RUN, Y0-SE or A-C (SAFE2) *2*3	Inverter operation state
OFF	-	-	-	OFF(Open)	Output shutoff (Safe state)
ON	Short	Short	No failure	ON(Close)	Drive enable
			Failure	OFF(Open)	Output shutoff (Safe state)
	Open	Open	No failure	ON(Close)	Output shutoff (Safe state)
			Failure	OFF(Open)	Output shutoff (Safe state)
	Short	Open	N/A	OFF(Open)	Output shutoff (Safe state)
	Open	Short	N/A	OFF(Open)	Output shutoff (Safe state)

"N/A" denotes a condition where circuit fault does not apply.

*1 At an internal safety circuit fault, one of E.SAF, E.6, E.7, and E.CPU is displayed on the operation panel. SA is displayed on the operation panel while S1 and S2 signals are both open and the safety function operates (without internal safety circuit fault).

*2 To use RUN or Y0 terminal for monitor output of failure detection, Pr. 190 should be set "81" (Safety monitor 2).

*3 To use A,C terminal for monitor output of failure detection, Pr. 192 should be set "81" (Safety monitor 2).

In case of diagnostic or functionality test, check the I/O state whether it is same or not as Table.5.

Diagnostic

If the failure detected, FR-E700-SC/NF/NC output alarm signal and indicate 'E.SAF' at the display.

In case of FR-E700-SC/NF/NC output the alarm, please take following action.

- (1) Check the S1-PC and S2-PC input signal logic is the same. If these are different logic, collect the input signal and reset the FR-E700-SC/NF/NC.
- (2) Disconnect the wire from S1, S2, PC terminal, then reset or power-off and on, If the 'SA' letter is flashed up at display, there is failure in system except FR-E700-SC/NF/NC. But, still 'E.SAF' is displayed and alarm output, there is malfunction on FR-E700-SC/NF/NC.

Self diagnostic test

FR-E700-SC/NF/NC does the self-diagnostic test on the power-ON.

If FR-E700-SC/NF/NC output alarm (SA, E.SAF) at power-up, please take the action described in 'Diagnostic' at above.

Test procedure for functionality

As depicted 'ATTENTION' in above, the test for the functionality is important.

Please do the test following procedure.

- (1) Please make each state of S1-PC and S2-PC depicted at Table.5.
- (2) If there is any different state from Table.5, FR-E700-SC/NF/NC has some malfunction.
- (3) If there is no different state from Table.5, check the systematic performance, such as, press the Emergency switch, press the start/restart button at the failure detected (RUN or Y0-SE opened), and so on.
- (4) Finally clear the error record of the FR-E700-SC/NF/NC (see the user manual how to clear the error record).

5. Safety parameters of FR-E700-SC/NF/NC

The safety parameters of FR-E700-SC/NF/NC are depicted as follows.

Table.6 Safety parameters of FR-E700-SC/NF/NC

Parameter	Value
PFD _{AVG}	5.0x10 ⁻⁴
PFH _D	6.0x10 ⁻⁹
PL	d
MTTF _D	300 years
DC _{AVG}	60%

REVISIONS

Revision Date	Manual Number	Revision
Mar. 2010	BCN-A211508-004-A	First edition
Aug. 2010	BCN-A211508-004-B	<u>Edited</u> Specification of SAFE signal
Jan. 2011	BCN-A211508-004-C	Correction of the applicable FR-E700-SC SERIAL number
Dec. 2011	BCN-A211508-004-D	<u>Added</u> FR-E700-NC Series
Nov. 2012	BCN-A211508-004-E	<u>Added</u> <ul style="list-style-type: none"> • Multiple inverter configuration example • Safety controller configuration example
Jul. 2013	BCN-A211508-004-F	<u>Added</u> Contact information on the back cover
Oct. 2013	BCN-A211508-004-G	<u>Edited</u> Multiple inverter configuration example
Aug. 2015	BCN-A211508-004-H	<u>Edited</u> Safety parameters
Oct. 2023	BCN-A211508-004-J	<u>Edited</u> <ul style="list-style-type: none"> • Functional safety standards • Safety parameters

HEADQUARTERS

Mitsubishi Electric Europe B.V. **EUROPE**
 Mitsubishi-Electric-Platz 1
D-40882 Ratingen
 Phone: +49 (0)2102 / 486-0
 Fax: +49 (0)2102 / 486-1120

Mitsubishi Electric Europe B.V. **CZECH REP.**
 Pekařská 621/7
CZ-155 00 Praha 5
 Phone: +420 255 719 200
 Fax: +420 251 551 471

Mitsubishi Electric Europe B.V. **FRANCE**
 25, Boulevard des Bouvets
F-92741 Nanterre Cedex
 Phone: +33 (0)1 / 55 68 55 68
 Fax: +33 (0)1 / 55 68 57 57

Mitsubishi Electric Europe B.V. **IRELAND**
 Westgate Business Park, Ballymount
IRL-Dublin 24
 Phone: +353 (0)1 4198800
 Fax: +353 (0)1 4198890

Mitsubishi Electric Europe B.V. **ITALY**
 Viale Colleoni 7 Palazzo Sirio
I-20864 Agrate Brianza (MB)
 Phone: +39 039 / 60 53 1
 Fax: +39 039 / 60 53 312

Mitsubishi Electric Europe B.V. **NETHERLANDS**
 Nijverheidsweg 23C
NL-3641RP Mijdrecht
 Phone: +31 (0) 297 250 350

Mitsubishi Electric Europe B.V. **POLAND**
 ul. Krakowska 50
PL-32-083 Balice
 Phone: +48 (0) 12 347 65 00
 Fax: +48 (0) 12 630 47 01

Mitsubishi Electric (Russia) LLC **RUSSIA**
 2 bld. 1, Letnikovskaya st.
RU-115114 Moscow
 Phone: +7 495 / 721 2070
 Fax: +7 495 / 721 2071

Mitsubishi Electric Europe B.V. **SPAIN**
 Carretera de Rubí 76-80 Apdo. 420
E-08190 Sant Cugat del Vallés (Barcelona)
 Phone: +34 (0) 93 / 5653131
 Fax: +34 (0) 93 / 5891579

Mitsubishi Electric Europe B.V. (Scandinavia) **SWEDEN**
 Hedvig Möllers gata 6,
SE- 223 55 Lund
 Phone: +46 (0) 8 625 10 00

Mitsubishi Electric Turkey Elektrik Ürünleri A.Ş. **TURKEY**
 Fabrika Otomasyonu Merkezi
 Şerifali Mahallesi Nutuk Sokak No.5
TR-34775 Ümraniye-İSTANBUL
 Phone: +90 (216) 969 25 00
 Fax: +90 (216) / 526 39 95

Mitsubishi Electric Europe B.V. **UK**
 Travellers Lane
UK-Hatfield, Herts. AL10 8XB
 Phone: +44 (0)1707 / 28 87 80
 Fax: +44 (0)1707 / 27 86 95

Mitsubishi Electric Europe B.V. **UAE**
 Dubai Silicon Oasis
United Arab Emirates - Dubai
 Phone: +971 4 3724716
 Fax: +971 4 3724721

Mitsubishi Electric Corporation **JAPAN**
 Tokyo Building 2-7-3
 Marunouchi, Chiyoda-ku
Tokyo 100-8310
 Phone: +81 (3) 3218-2111
 Fax: +81 (3) 3218-2185

Mitsubishi Electric Automation, Inc. **USA**
 500 Corporate Woods Parkway
Vernon Hills, IL 60061
 Phone: +1 (847) 478-2100
 Fax: +1 (847) 478-0328

EUROPEAN REPRESENTATIVES

GEVA **AUSTRIA**
 Wiener Straße 89
A-2500 Baden
 Phone: +43 (0)2252 / 85 55 20
 Fax: +43 (0)2252 / 488 60

OOO TECHNIKON **BELARUS**
 Prospect Nezavisimosti 177-9
BY-220125 Minsk
 Phone: +375 (0)17 / 393 1177
 Fax: +375 (0)17 / 393 0081

INEA RBT d.o.o. **BOSNIA AND HERZEGOVINA**
 Stegne 11
SI-1000 Ljubljana
 Phone: +386 (0)1 / 513 8116
 Fax: +386 (0)1 / 513 8170

AKHNATON **BULGARIA**
 4, Andrei Ljapchev Blvd., PO Box 21
BG-1756 Sofia
 Phone: +359 (0)2 / 817 6000
 Fax: +359 (0)2 / 97 44 06 1

INEA CR **CROATIA**
 Losinjska 4 a
HR-10000 Zagreb
 Phone: +385 (0)1 / 36 940 - 01 / -02 / -03
 Fax: +385 (0)1 / 36 940 - 03

AutoCont C. S. S.R.O. **CZECH REPUBLIC**
 Kafkova 1853/3
CZ-702 00 Ostrava 2
 Phone: +420 595 691 150
 Fax: +420 595 691 199

HANS FØLSGAARD A/S **DENMARK**
 Theilgaard's Torv 1
DK-4600 Køge
 Phone: +45 4320 8600
 Fax: +45 4396 8855

Electrobit OÜ **ESTONIA**
 Pärnu mnt. 160i
EST-11317, Tallinn
 Phone: +372 6518 140

UTU Automation Oy **FINLAND**
 Peltotie 37i
FIN-28400 Ulvila
 Phone: +358 (0)207 / 463 500
 Fax: +358 207 / 463 501

UTEKO A.B.E.E. **GREECE**
 5, Mavrogenous Str.
GR-18542 Piraeus
 Phone: +30 (0)211 / 1206-900
 Fax: +30 (0)211 / 1206-999

MELTRADE Kft. **HUNGARY**
 Fertő utca 14.
HU-1107 Budapest
 Phone: +36 (0)1 / 431-9726
 Fax: +36 (0)1 / 431-9727

OAK Integrator Products SIA **LATVIA**
 Rītausmas iela 23
LV-1058 Rīga
 Phone: +371 67842280

Automatikos Centras, UAB **LITHUANIA**
 Neries krantinė 14A-101
LT-48397 Kaunas
 Phone: +370 37 262707
 Fax: +370 37 455605

ALFATRADE Ltd. **MALTA**
 99, Paola Hill
Malta-Paola PLA 1702
 Phone: +356 (0)21 / 697 816
 Fax: +356 (0)21 / 697 817

EUROPEAN REPRESENTATIVES

INTEHSIS SRL **MOLDOVA**
 bld. Traian 23/1
MD-2060 Kishinev
 Phone: +373 (0)22 / 66 4242
 Fax: +373 (0)22 / 66 4280

Fonseca S.A. **PORTUGAL**
 R. João Francisco do Casal 87/89
PT-3801-997 Aveiro, Esgueira
 Phone: +351 (0)234 / 303 900
 Fax: +351 (0)234 / 303 910

SIRIUS TRADING & SERVICES SRL **ROMANIA**
 Aleea Lacul Morii Nr. 3
RO-060841 Bucuresti, Sector 6
 Phone: +40 (0)21 / 430 40 06
 Fax: +40 (0)21 / 430 40 02

INEA SR d.o.o. **SERBIA**
 Ul. Karadjordjeva 12/217
SER-11300 Smederevo
 Phone: +386 (026) 461 54 01

SIMAP SK (Západné Slovensko) **SLOVAKIA**
 Dolné Pažite 603/97
SK-911 06 Trenčín
 Phone: +421 (0)32 743 04 72
 Fax: +421 (0)32 743 75 20

INEA RBT d.o.o. **SLOVENIA**
 Stegne 11
SI-1000 Ljubljana
 Phone: +386 (0)1 / 513 8116
 Fax: +386 (0)1 / 513 8170

OMNI RAY AG **SWITZERLAND**
 Im Schörl 5
CH-8600 Dübendorf
 Phone: +41 (0)44 / 802 28 80
 Fax: +41 (0)44 / 802 28 28

CSC- AUTOMATION Ltd. **UKRAINE**
 4 B, Yevhena Sverstyuka Str.
UA-02002 Kiev
 Phone: +380 (0)44 / 494 33 44
 Fax: +380 (0)44 / 494-33-66

EURASIAN REPRESENTATIVES

TOO Kazpromavtomatika **KAZAKHSTAN**
 UL. ZHAMBYLA 28,
KAZ-100017 Karaganda
 Phone: +7 7212 / 50 10 00
 Fax: +7 7212 / 50 11 50

MIDDLE EAST REPRESENTATIVE

EIM Energy **EGYPT**
 3 Roxy Square
ET-11341 Heliopolis, Cairo
 Phone: +202 24552559
 Fax: +202 245266116

SHERF Motion Techn. Ltd. **ISRAEL**
 Rehov Hamerkava 19
IL-58851 Holon
 Phone: +972 (0)3 / 559 54 62
 Fax: +972 (0)3 / 556 01 82

CEG LIBAN **LEBANON**
 Cebaco Center/Block A Autostrade DORA
Lebanon-Beirut
 Phone: +961 (0)1 / 240 445
 Fax: +961 (0)1 / 240 193

AFRICAN REPRESENTATIVE

ADROIT TECHNOLOGIES **SOUTH AFRICA**
 20 Waterford Office Park 189 Witkoppen Road
ZA-Fourways
 Phone: + 27 (0)11 / 658 8100
 Fax: + 27 (0)11 / 658 8101

If you want to inquiry price, you can contact below:

Email: anna@cwlyautomation.com
 Tel: +86 136 67121125 whatsapp/ VK/ Telegram also available
 Company: CW Green Tech

If you want to inquiry price, you can contact below:

Email: anna@cwlyautomation.com
 Tel: +86 136 67121125 whatsapp/ VK/ Telegram also available
 Company: CW Green Tech

If you want to inquiry price, you can contact below:

Email: anna@cwlyautomation.com
 Tel: +86 136 67121125 whatsapp/ VK/ Telegram also available
 Company: CW Green Tech

MITSUBISHI ELECTRIC CORPORATION

HEAD OFFICE: TOKYO BUILDING 2-7-3, MARUNOUCHI, CHIYODA-KU, TOKYO 100-8310, JAPAN